

THE INFORMATION CONTAINED IN THIS DRAWING IS THE SOLE PROPERTY OF ANDERSON POWER PRODUCTS. ANY REPRODUCTION IN PART OR WHOLE WITHOUT THE WRITTEN PERMISSION OF ANDERSON POWER PRODUCTS IS PROHIBITED.

REV.	DESCRIPTION OF CHANGES	BY:	DATE
1	ECRN: 13225	CMS	7/1/99

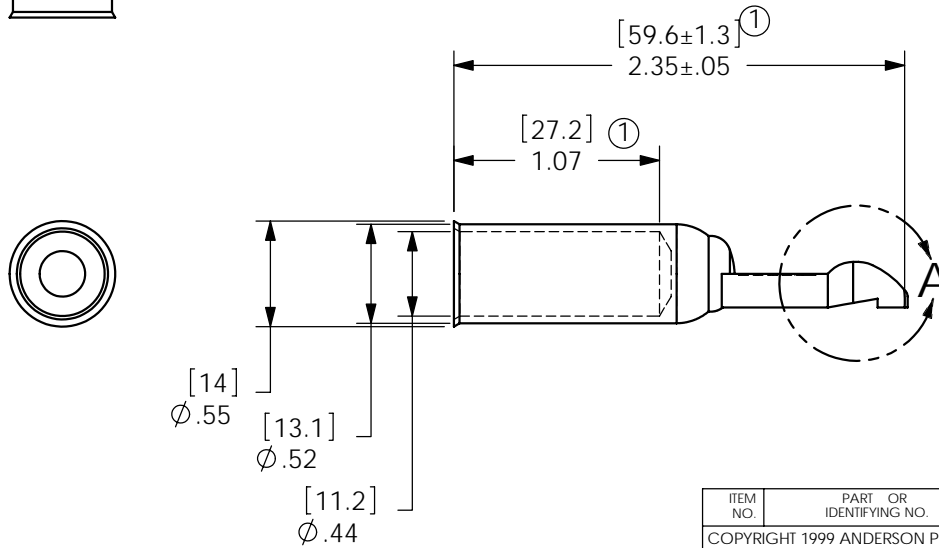
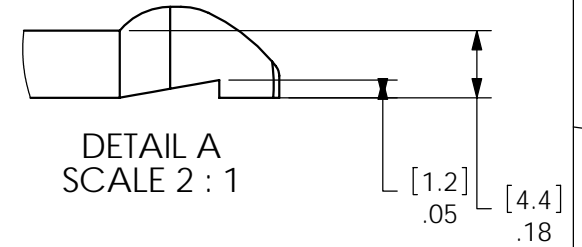
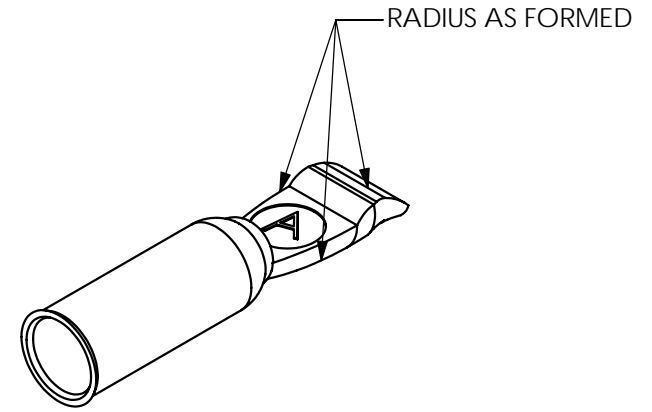
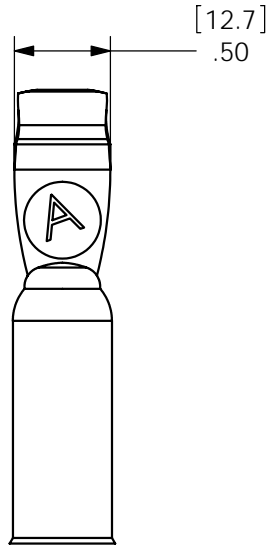

ITEM NO.	PART OR IDENTIFYING NO.	NOMENCLATURE OR DESCRIPTION	MATERIAL SPECIFICATION	QTY RECD
COPYRIGHT 1999 ANDERSON POWER PRODUCTS. ALL RIGHTS RESERVED. UNAUTHORIZED REPRODUCTION HEREBY PROHIBITED.				
DIMENSIONS ARE IN INCHES DIMENSIONS IN PARENTHESES [ ] ARE IN MILLIMETERS		CAD GENERATED DRAWING, DO NOT MANUALLY UPDATE		ANDERSON POWER PRODUCTS
TOLERANCES ARE: 2PL- ±.02 [±.5]		APPROVALS	DATE	
		DRAWN AC	3/13/95	<b>CATALOG NUMBER 1382</b> <b>PP180/SB175 CONTACT</b> <b>#1/0 AWG WIRE</b>
		CHECKED MRD	3/16/95	
		RESP ENG UFN	3/27/95	
		MFG ENG CHB	3/27/95	
		QUAL ENG UFN	3/28/95	
NEXT ASSY	USED ON	FINISH		SIZE A
		COPPER		SPECIFICATION:
		SILVER PLATE		113878S1
APPLICATION	DO NOT SCALE DRAWING	SCALE NONE	CADFILES/01065	REV. 1
			SHEET 1 OF 1	